

ASSEMBLY

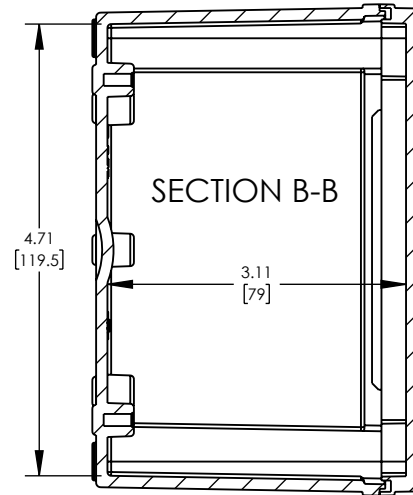

NOTES:

1. MATERIAL: BODY - POLYCARBONATE 10% FIBERGLASS REINFORCED
COVER - POLYCARBONATE
UL508 /NEMA TYPE 4X WITH IP-67 TUV RATING & UL-94V0 RATING
2. FINISH: BODY - LIGHT GRAY
COVER - LIGHT GRAY OR CLEAR (-C)
3. SUPPLIED WITH FOUR NON-METALLIC CAPTIVE SCREWS FOR COVERMOUNTING
4. CONTINUOUS GASKET IN COVER
5. SUPPLIED WITH FOUR M4 x 8mm LG. TRUSS HEAD MACHINE SCREWS
6. DIMENSIONS ARE INCH [MM]
7. DRAWING FOR REFERENCE
8. OPTIONAL ACCESSORIES:
INTERNAL STEEL PANEL - #PIX-11760
MOUNTING BRACKET KIT (STAINLESS STEEL) - #NBX-10922
MOUNTING BRACKET KIT (PLASTIC) - #PIX-4117

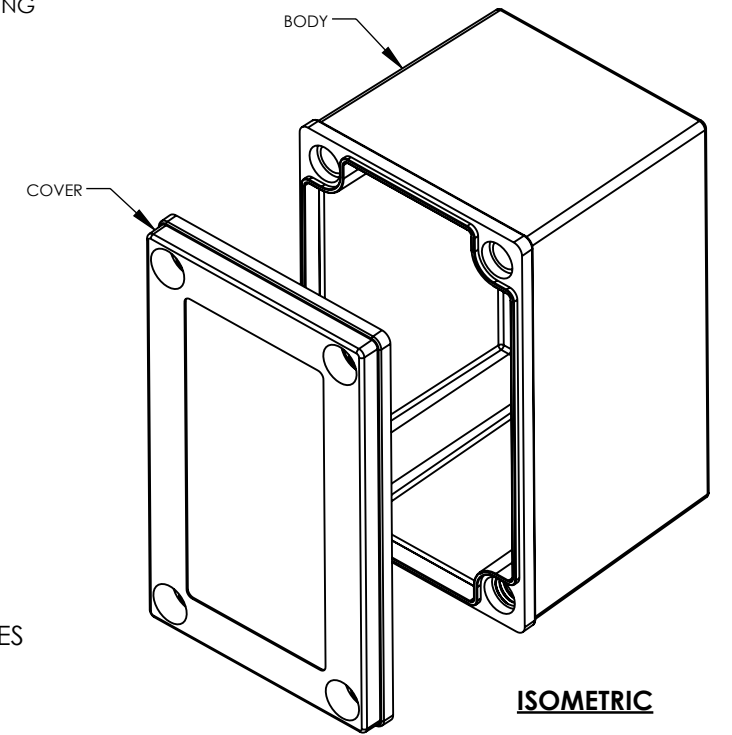

ISOMETRIC

DRAWING FOR REFERENCE
WE RESERVE THE RIGHT TO MAKE CHANGES TO OUR STANDARD PRODUCTS. PLEASE CONSULT WITH BUD INDUSTRIES PRIOR TO USING THIS DRAWING FOR DESIGN PURPOSE.

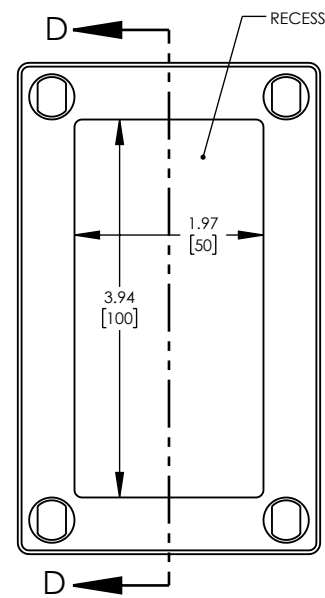

COVER - TOP VIEW

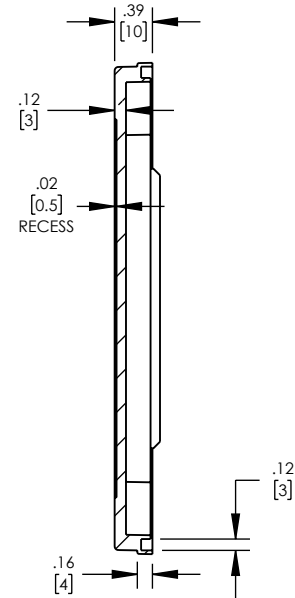

SECTION D-D
COVER

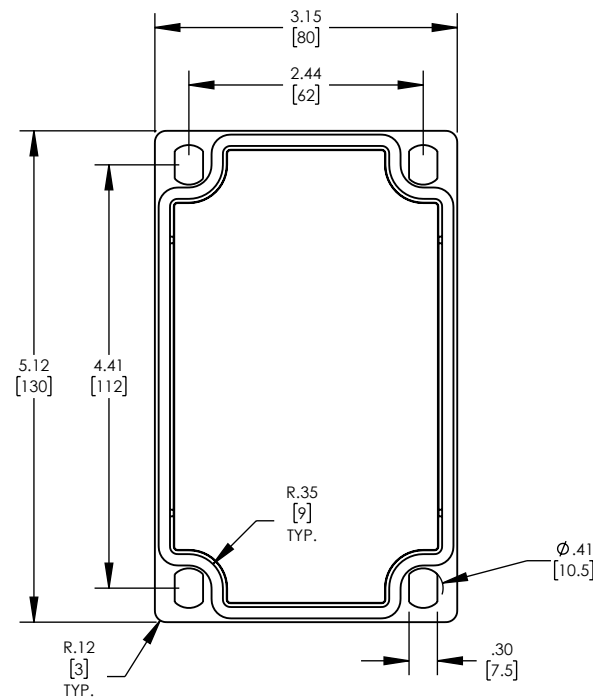

COVER - BACK VIEW

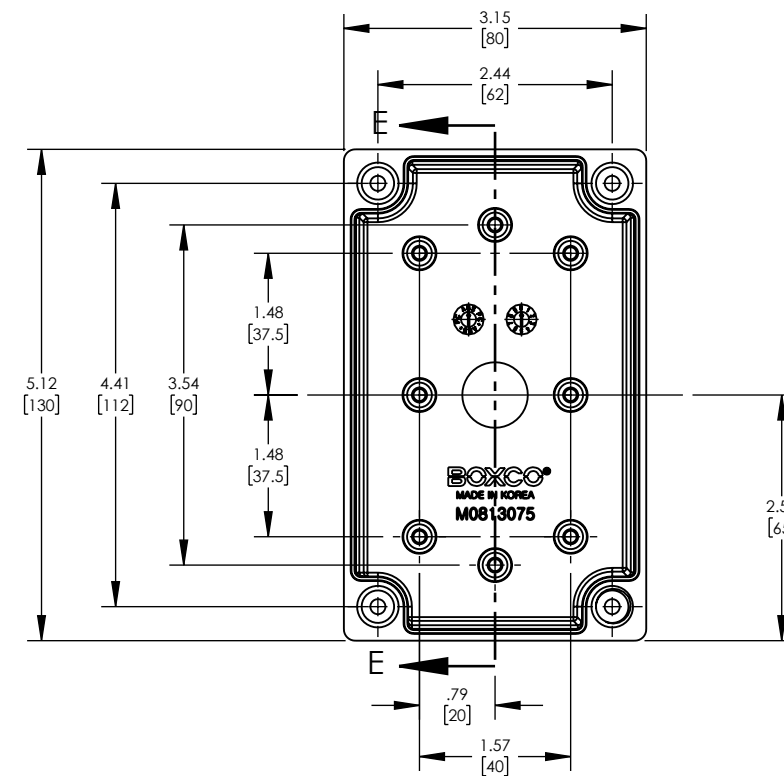

BODY

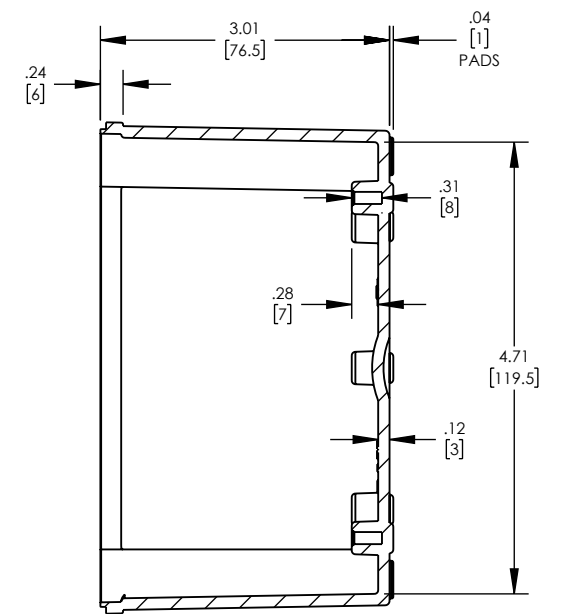

SECTION E-E