

DRAWING FOR REFERENCE

WE RESERVE THE RIGHT TO MAKE CHANGES TO OUR STANDARD PRODUCTS. PLEASE CONSULT WITH BUD INDUSTRIES PRIOR TO USING THIS DRAWING FOR DESIGN PURPOSE.

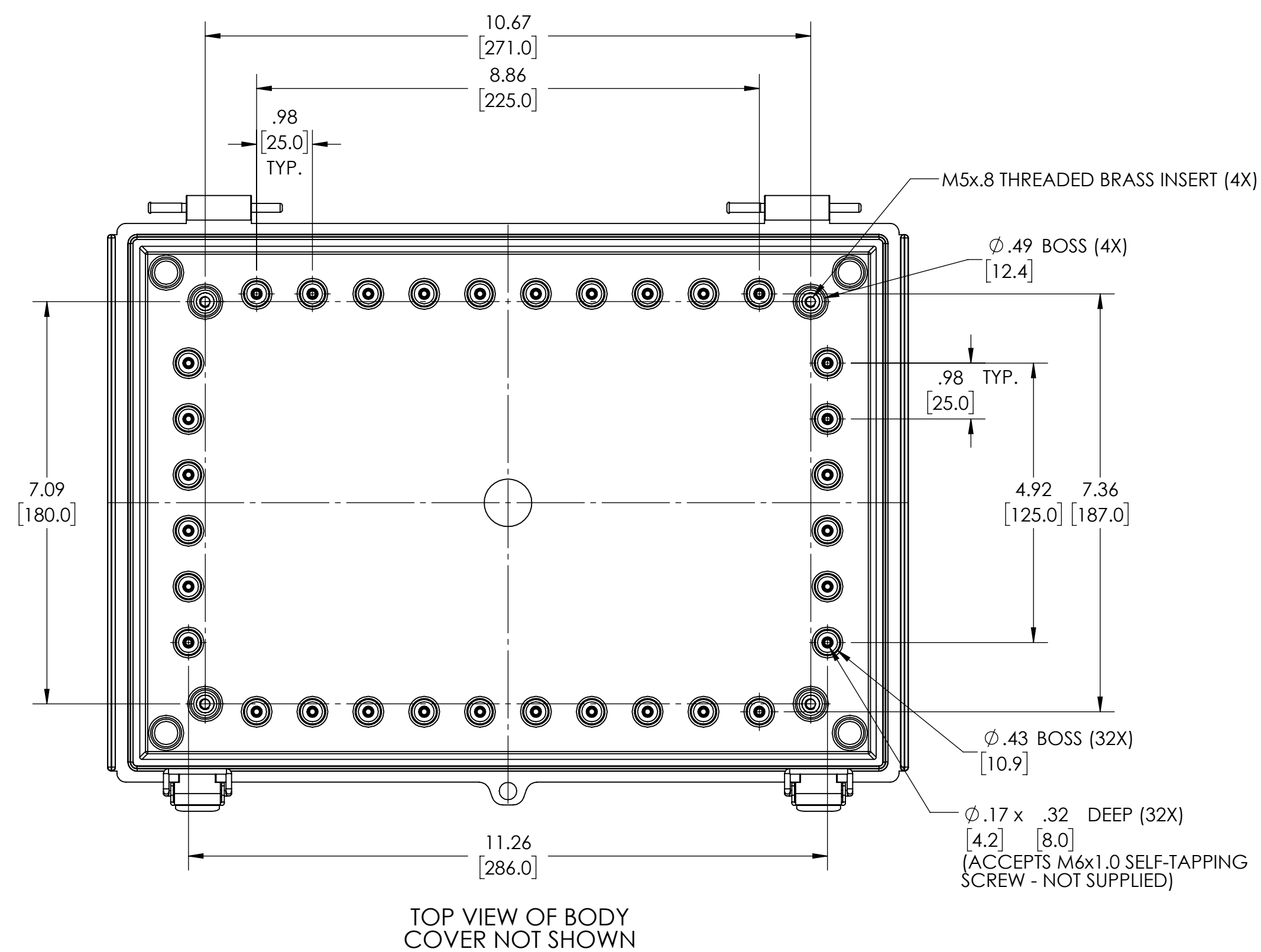
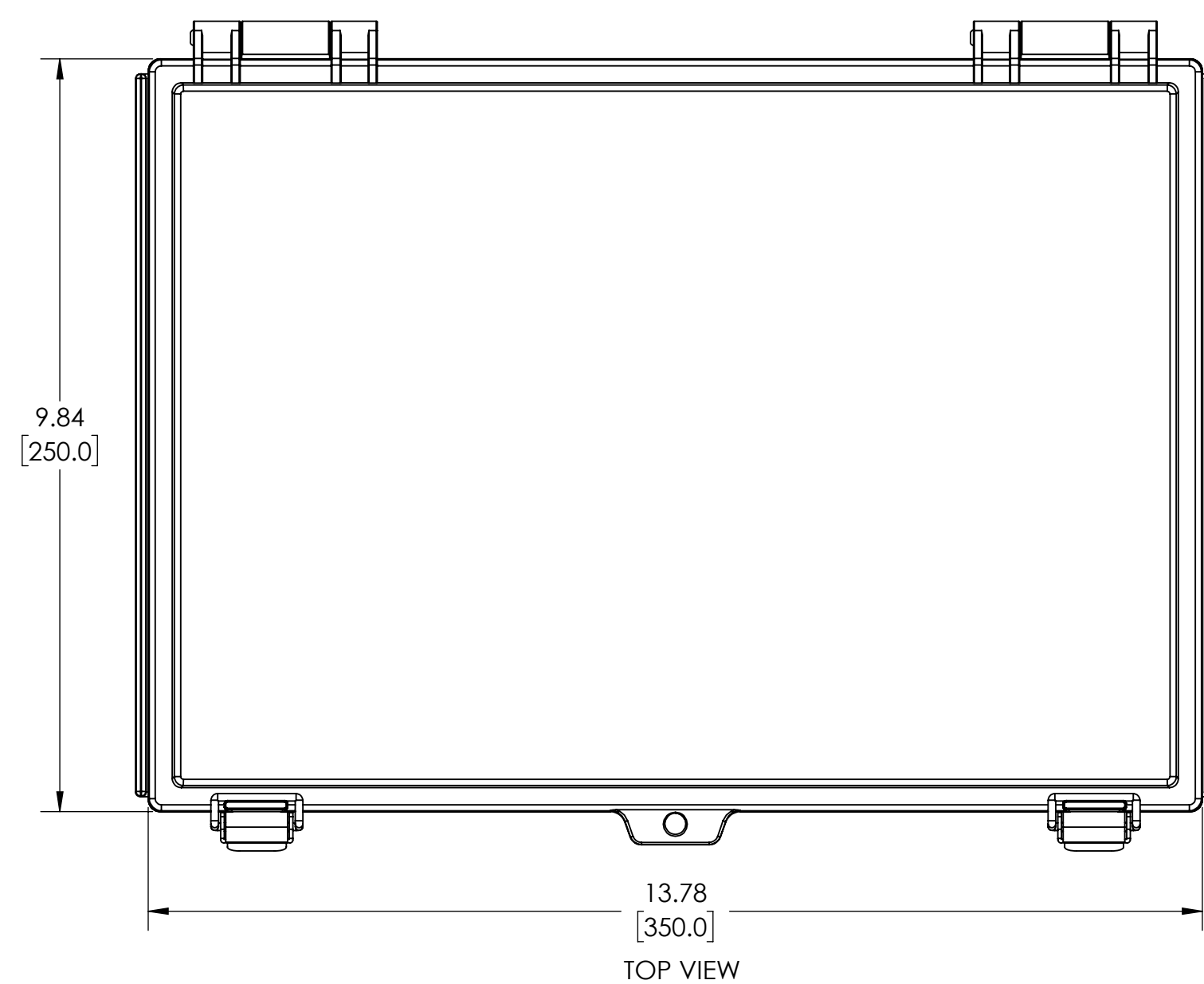

NOTES:

- MATERIAL: BODY - LIGHT GRAY POLYCARBONATE RESIN 10% GLASS FIBER FILLED. COVER - LIGHT GRAY POLYCARBONATE OR CLEAR (-C SUFFIX PART NO.)
 - UL508 / NEMA TYPE 4X WITH IP-67 TUV RATING (MEETS NEMA TYPE 6), UL 94 V-0 AND UL 94-5VA
 - RoHS COMPLIANT
 - 40°C TO +95°C EXTENDED EXPOSURE CONDITION
 - CONTINUOUS Poured GASKET IN COVER
 - SUPPLIED WITH FOUR M5x.8 x 10mm LG. TRUSS HEAD ZINC PLATED STEEL MACHINE SCREWS (ITEMS NOT SHOWN)
 - DIMENSIONS ARE INCH [MM]
- OPTIONAL ACCESSORIES:
 INTERNAL STEEL PANEL #PTX-22428
 INTERNAL PLASTIC PANEL #PTX-22428-P
 MOUNTING BRACKET KIT (STAINLESS STEEL) #NBX-10922

